

2100-IS RS232 to RS422\485 Converter.

Converts and Isolates RS232 from a computer to RS422 or RS485 for communication to a field Datalogging system.



Features.

- Audible & Relay Alarms for Communication Failure.
- Easy to Install.
- LED Status Indications.
- Compact Desk Top Box.
- Low Cost.
- Selectable Alarm Time Delays.
- Isolation Between Field Units & Computer.
- Complete With Serial Cable & 2m Power Cord.



Other 2100 models include:
2100-A16 :16AI, 3DI, 2 Relay Out;
2100-A4 :4AI, 4DI, 4 Relay Out;
2100-A4e :4AI, 4DI, 8 Relay Out;
2100-D :12DI, 12 Relay Out;
2100-ME :Memory Expansion for 2100-A;
2100-M :16AI Multiplexer;
2100-NS :Non-Isolated RS232 to RS422;
2100-R :16 Relay Expansion for 2100-A.

Ordering Information.

Standard Unit:

2100-IS Isolated RS232 to RS422/485 Converter.

Accessories:

2100-IRT Adaptor Kit for Tait TA348 RF Radio Modem.
2100-IRG Adaptor Kit for Gigatek RDL-201 RF Radio Modem.
2100-IM Adaptor Kit for Standard Telephone Modem.
2100-IP RS232 Cable for Parallel Connection of up to Four 2100-IS Convertors.
2100-IB Adaptor Kit for Boosting RS422/485.

Description.

The 2100-IS is a compact, desktop module that isolates and converts RS232 from a computer to RS422 or RS485 for communication to a field data logging system. Its driver and receiver meet EIA standards RS-422-A and CCITT recommendations V.11 and X.27, and are designed for multipoint transmission on long bus lines in noisy environments. It includes thermal shutdown and over current limiting. The 2100-IS includes audible and fail safe alarms of communications failure, with selectable time delays. It is capable of interfacing to telephone modems, and RF modems. Its internal mains supply powers both sides of the isolation barrier, making it suitable for working with many types of PCs and PLCs. It comes complete with a 2m RS232 cable with a selection of either a 9 way or 25 way connector for the PC.



2100-IS
Front View

Quality Assurance Programme.

The modern technology and strict procedures of the ISO9001 Quality Assurance Programme applied during design, development, production and final inspection grant long term reliability of the instrument. This instrument has been designed and built to comply with EMC and Safety Standards requirements.

2100-IS Installation Guide Index.

Description and Ordering Information	page 1
Specifications, LED Functions, Alarm Description.	page 2
Circuit Board Layout, Switch Functions.	page 3
RS 422 and RS485 Serial Connections.	page 4
Data Cable Installations.	page 5
RS232 and RS422/485 Booster. Modem Connections.	page 6
Multiple Parallel 2100-IS. DB25 Pinout.	page 7
Commissioning and Maintenance	page 8

Specifications.

Comms Baud Rate	-Standard	9600baud.
	-Optional	4800 or 19200baud.
Comms Input / Output Isolation		1.0kV ac/dc for 1min.
Power Supply		230/115Vac±10%, 50/100mA, 50/60Hz.
EMC Emissions Compliance		EN 55022-A
EMC Immunity Compliance		EN 50082-1
Safety Compliance.		EN 60950
Operating Temperature		0~60C.
Storage Temperature		-20~80C.
Operating Humidity		90%RH Max. Non-Condensing.
Housing		Desk Top Metal Box.
Dimensions		L=130, W=115, H=58.
Weight		1300g. (Includes Cables.)
Alarm Relay		1A @ 24Vdc Max.

Note 1. Specifications based on Standard Calibration Unit, unless otherwise specified.

Note 2. Due to ongoing research and development, designs, specifications, and documentation are subject to change without notification.
No liability will be accepted for errors, omissions or amendments to this specification.



CAUTION: Dangerous voltages may be present. The 2100-IS has no user serviceable parts.
Protective enclosure only to be opened by qualified personnel.
Remove ALL power sources before removing protective cover.



Description of LED Functions.

R.X.	LED	ON	Unit Receiving Data From the Field.
T.X.	LED	ON	Unit Transmitting Data to the Field.
T.X.E.	LED	ON	Transmit Enable Line Active.
ALARM	LED	ON	Unit in Alarm.
PWR	LED	ON	Unit has Power Connected.
RESET	Switch		Push this Switch to Reset the Alarm. This does not reset the computer. (See Description of Alarm Function).

Description of Alarm Function.

Note: In the description below we have selected an alarm time delay of 4 minutes, Audible is active, Relay is active, and Time Out is active.

After approx. 4 minutes of the last RX data having been received the audible, relay and LED alarms activate. If more RX data is received after the unit has gone into alarm the alarms remain active until the RESET button is pushed.

- (1) When the RESET button is pushed the audible, relay and LED alarms reset.
- (2) If after approx. 1 hour of the RESET button being pushed no data has been received the alarm 'times out', and the audible, relay and LED alarms reactivate

Notes:

- (1) To deactivate the audible alarm only, place S1-6 ON.
- (2) To deactivate all audible, relay and LED alarms, place all S1 switches OFF.
- (3) To deactivate the 1 hour time out function, place S2-6 OFF.

2100-IS Circuit Board Layout.

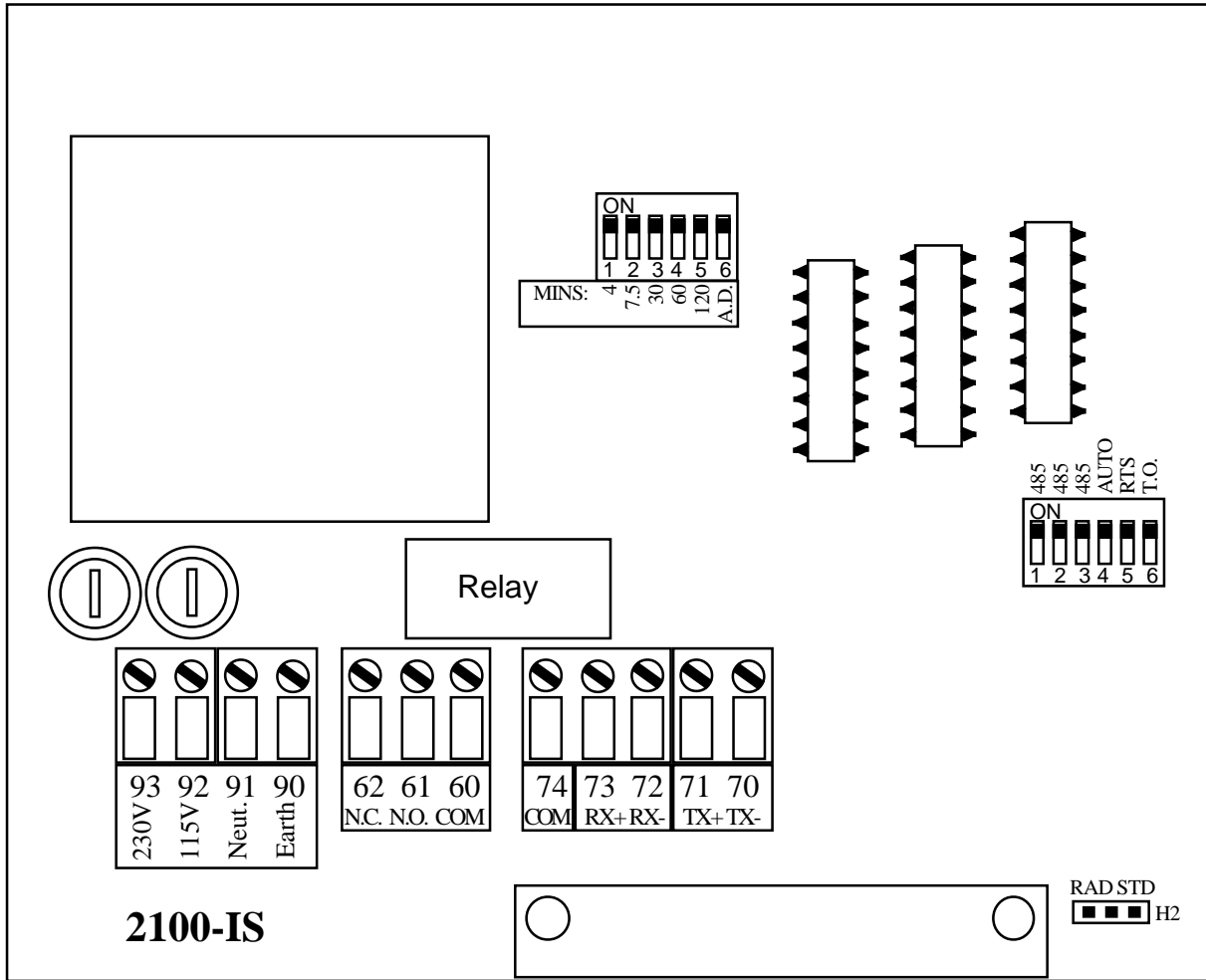

S1 Selectable Alarm Time Delays.

6 Way DIP Switch

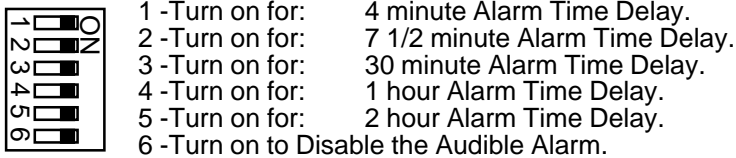

- Notes 1/ Only 1 of DIP switches 1 to 5 should be on at any one time.
 2/ To disable all the alarms put all S1 DIP switches OFF.
 3/ All alarm time delays are approximate only.

S2 Description of Switch Settings.

6 Way DIP Switch

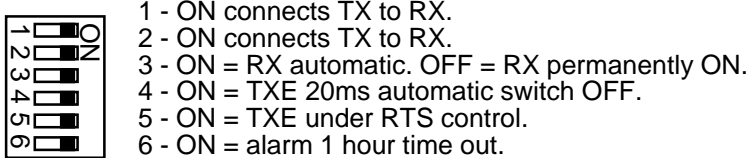

- Notes 1/ Only 1 of DIP switches 4 and 5 should be on at any one time.

422/485 Mode Settings.

6 Way DIP Switch

RS422/485 Mode Settings.				
DIP Switch		422-Microscan	485-Microscan	485-RTS Control
	1	OFF	ON	ON
	2	OFF	ON	ON
	3	OFF	ON	ON
	4	OFF	ON	OFF
	5	OFF	OFF	ON
	6	Refer to description of alarm function.		

OUTSTATION LAYOUT.
2-Wire RS485 Serial Connections.

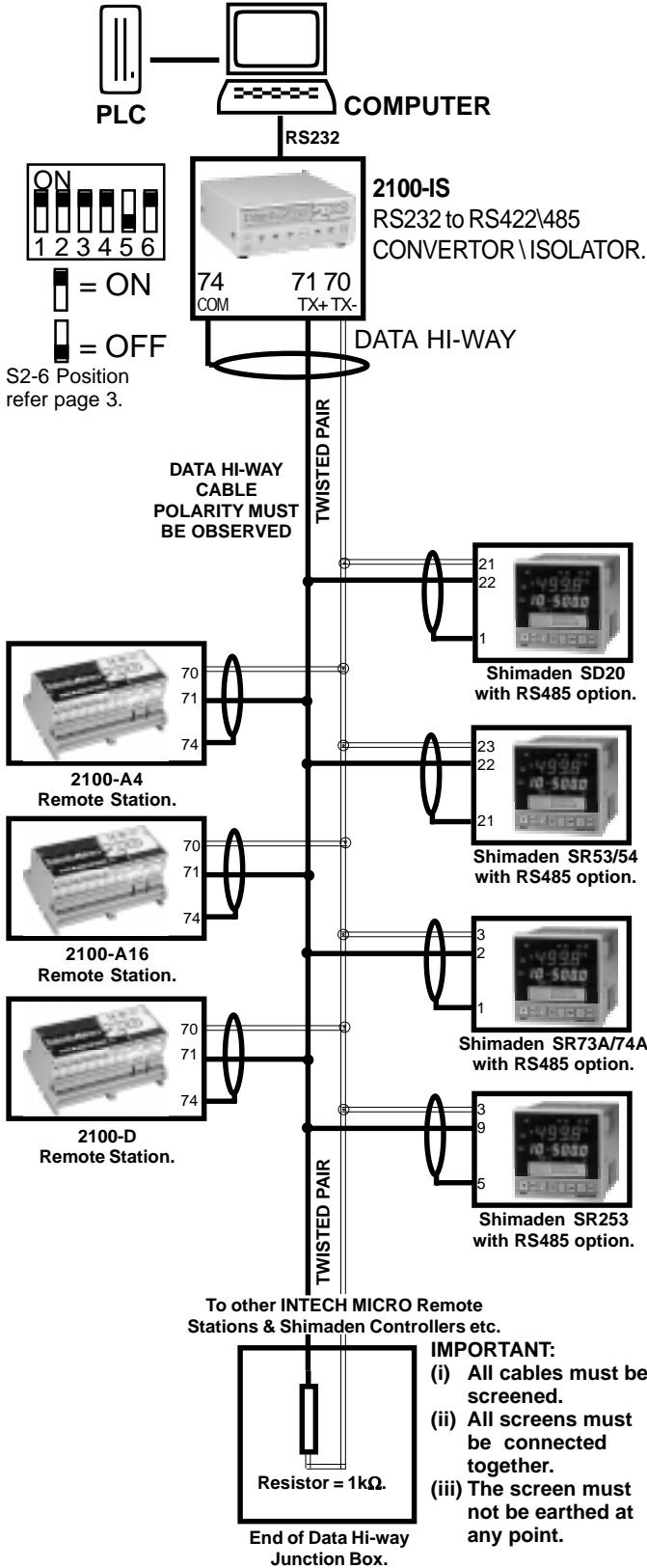

- Notes:
- (i) RS485 can only be used with software release IQ99 onwards.
 - (ii) RS485 Data Hi-way is not compatible with RS422 Data Hi-way devices such as IN-2000-AI, IN-2000-AO, IN-2000-DI, IN-2000-DO, FP21, SR25, etc. The two Data Hi-ways must be run independent of each other, using two separate 2100-IS*, that share the same RS232. Refer to parallel connection of RS232 into multiple 2100-IS*, on page 7.

- IMPORTANT:
- (i) All cables must be screened.
 - (ii) All screens must be connected together.
 - (iii) The screen must not be earthed at any point.

OUTSTATION LAYOUT.
4-Wire RS422 Serial Connections.

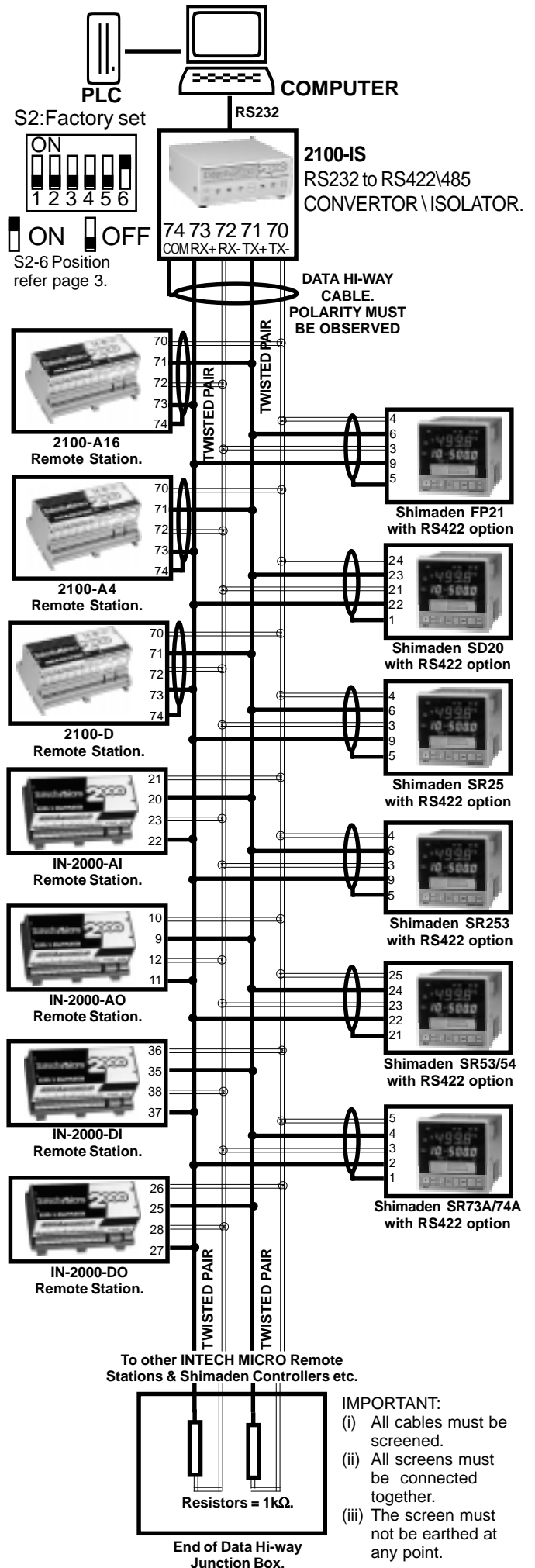

2100 SCADA.

RS422/485 Data Cabling Installation eg 1.

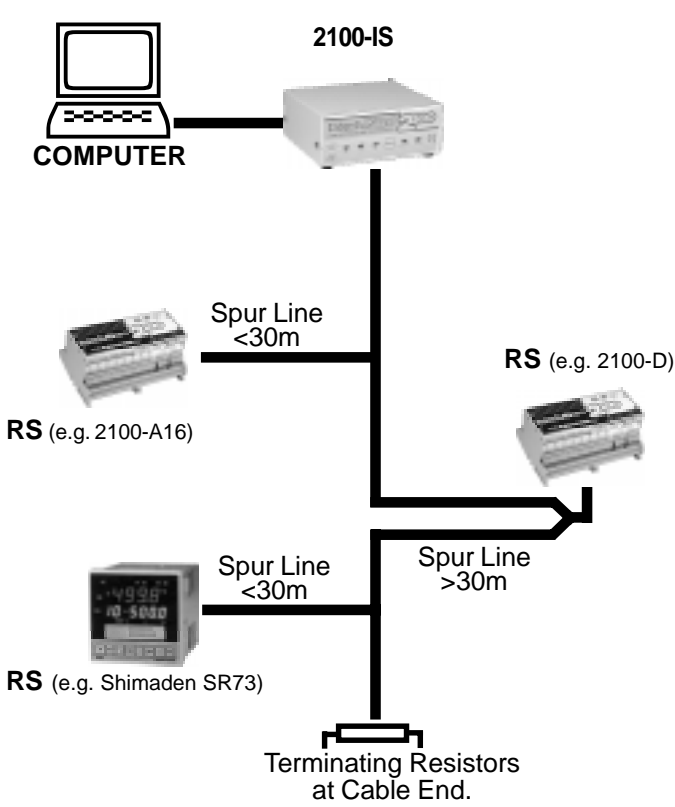

RS422/485 Data Cabling Installation eg 2.

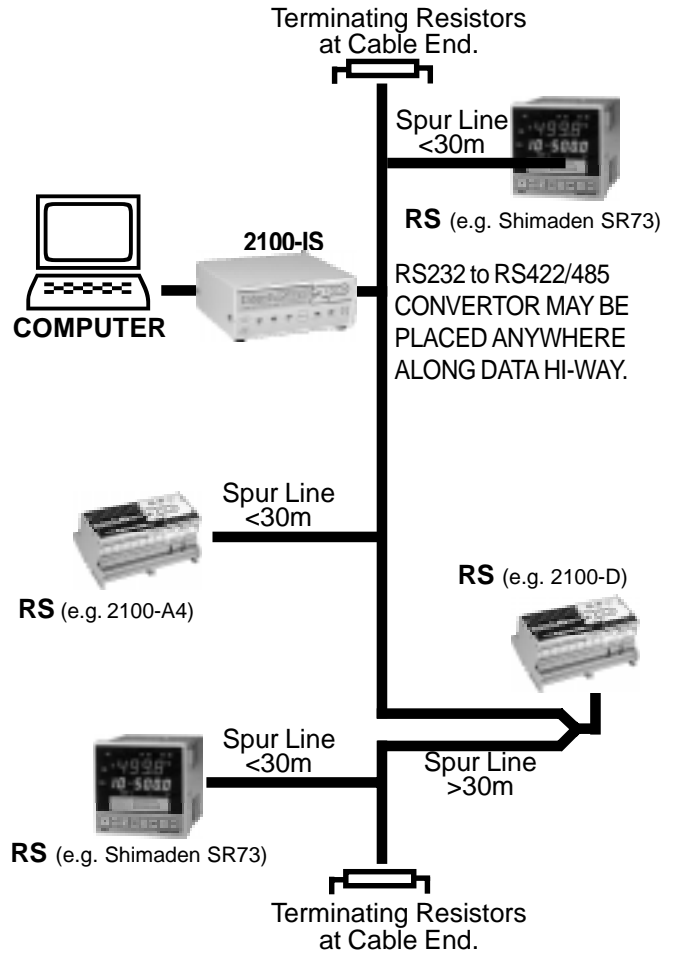

Note: RS = MICRO 2000 or 2100 Remote Stations, or SHIMADEN CONTROLLERS.
IMPORTANT: The accompanying Installation Instructions must be strictly adhered to.

Terminations for all Models of 2100-IS / 2100-NS / IN-2000-IS.

Terminations								
Model	2100-IS		2100-NS		IN-2000-IS Rev.2		IN-2000-IS Rev.0, Rev.1	
	Term No	Connection	Term No	Connection	Term No	Connection	Term No	Connection
Mains Supply	93	230Vac			1	Phase(24~230Vac)	1	230Vac
	92	115Vac			2	Neutral	2	115Vac
	91	Neutral			3	Earth	3	Neutral
	90	Earth			4	Earth	4	Earth
Alarm Relay	62	N.C.			5	N.C.	5	N.C.
	61	N.O.			6	N.O.	6	N.O.
	60	COM			7	COM	7	COM
RS422 (RS485)			75	9Vdc, 200mA	8	0V	8	0V
			74	COM	9	RX+	9	RX+
			73	RX+	10	RX-	10	RX-
			72	RX-	11	0V	11	0V
			71	TX+ (RS485)	12	TX+	12	TX+
			70	TX- (RS485)	13	TX-	13	TX-

RS232 Booster Connection Diagram.

Where the RS232 is required to exceed it's specified cable length of 15m, two or more 2100-IS' can be used to extend the signal up to 1200m. (To extend further refer to the following section, using the 2100-IB Booster Adapter.)

Note.

- (1) This cannot be used for hardware handshaking.
- (2) PLC to use pin 4 (RS232 RTS) multidrop operation. Set S2-5 'ON'.

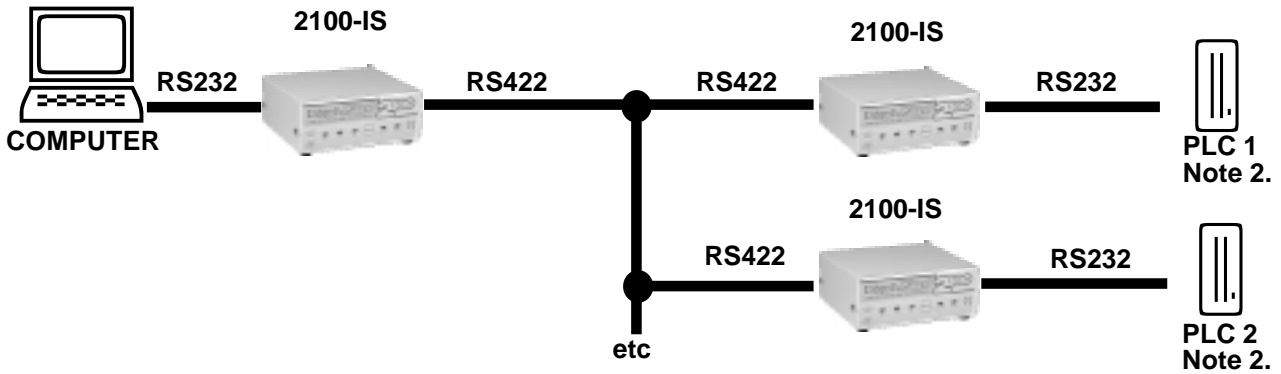

RS422/485 Booster Connection Diagram.

Where the RS422/485 Data Hi-way exceeds 1200m it is necessary to boost the signal.

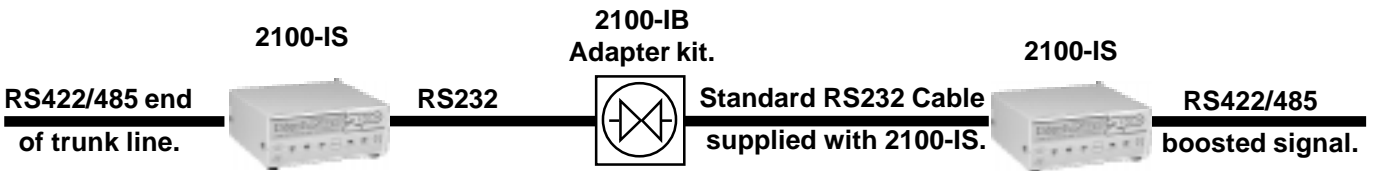

Note: Detailed connection information supplied with 2100-IB Adapter Kit.

2100-IS Modem Connection Diagrams.

Tait TA348 RF modem connection.

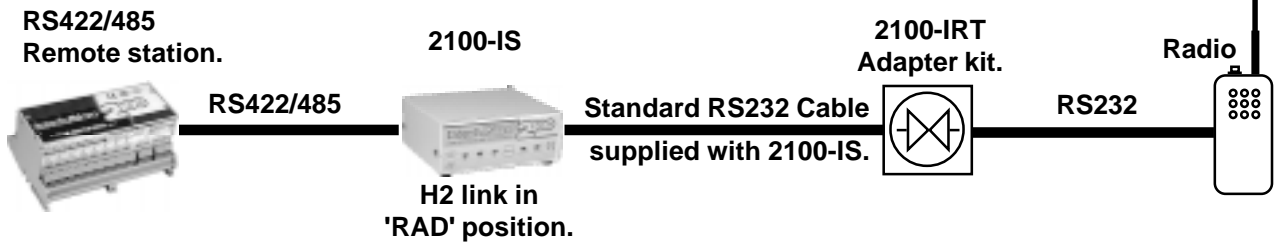

Gigatek RDL-201 RF modem connection.

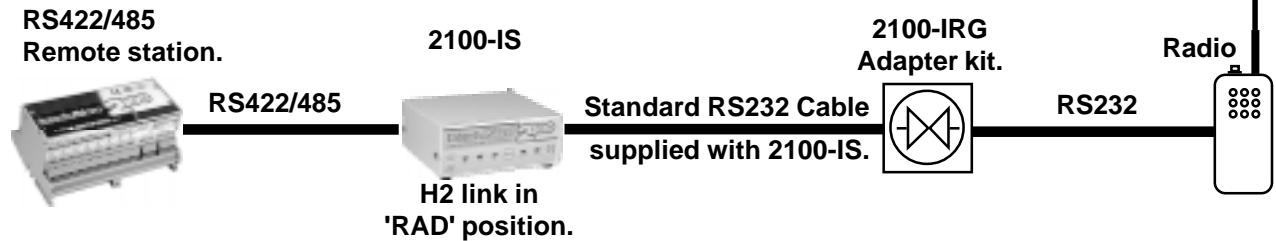

Standard modem connection.



Note: Detailed connection information supplied with each 2100 Modem Adapter Kit.

Parallel Connection of RS232 to Multiple 2100-IS'

Used in situations where the RS422/485 Data Hi-way is going in different directions in a plant. Up to six 2100-IS' can be connected in this configuration.

Note: If the overall Data Hi-way does not exceed 1200m, one 2100-IS should be sufficient.

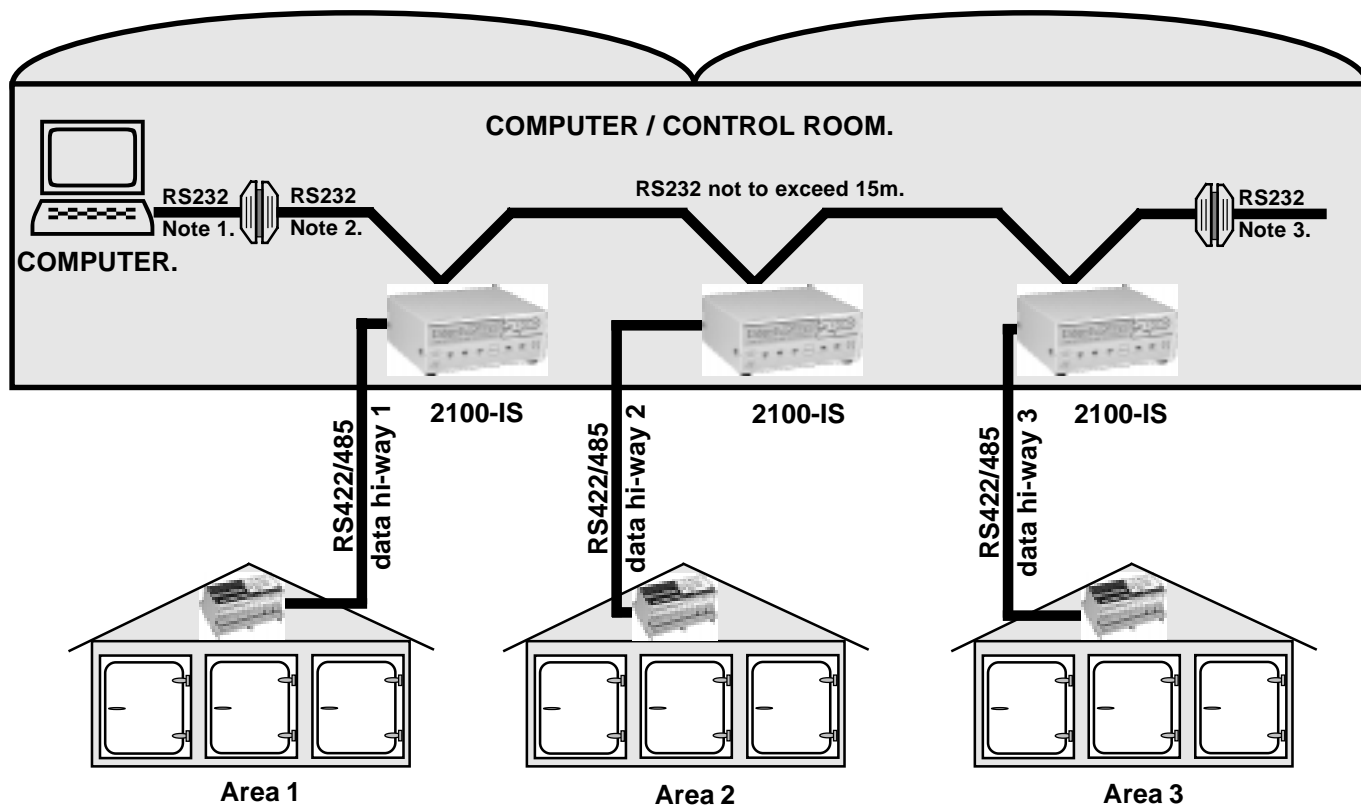

Note.

- (1) RS232 Cable supplied with 2100-IS.
- (2) 2100-IP RS232 cable for parallel connection of up to four 2100-IS convertors.
- (3) For connection of more than four 2100-IS', two 2100-IP cables can be connected together.
- (4) This mode is not to be confused with the interfaces "Dual Port Mode" which is used to access more than 32 Shimaden Controllers on two serial ports.
- (5) To parallel a 2100-IS with an IN-2000-IS remove any links from H2 on the 2100-IS.

2100-IS Pinout of DB25 Connector.

2100-IS = DCE. (Data Communications Equipment.)

2100-IS DB25 Connector						
Pin Name	Signal Name	Direction	Pin No.	H2 STD	H2 RAD	H2 Open
TD	Transmitted Data	In	2	TX	TX	TX
RD	Received Data	Out	3	RX	RX	RX
RTS	Request to Send	In	4	TXE	Radio CTS	TXE
CTS	Clear to Send	Out	5	CTS		N/C
SG	Signal Ground	-	7	0V	0V	0V
DSR	Data Ready to Send	In	6	linked	linked	linked
CD	Carrier Detect	Out	8			
DTR	Data Terminal Ready	Out	20			
RI	Ring Indicator	N/C	22	N/C	N/C	N/C

Note: For position of header H2 refer to Circuit Board Diagram, page 3.

The Proper Installation & Wiring of the 2100-IS.

MOUNTING.

- (1) Mount in a clean environment.
- (2) Do not subject to vibration, excess temperature or humidity variations.
- (3) Avoid mounting near power control equipment.

ANALOGUE SIGNAL CABLING.

- (1) All analogue cables should be good quality, overall screened, INSTRUMENTATION CABLE, with the screen earthed at one end only. (e.g. Austral Standard Cables B5102ES.)
- (2) Analogue signal cables should be laid a minimum distance of 300mm from power and data cables.
- (3) It is recommended that you do not ground current loops or use power supplies with ungrounded outputs.
- (4) Lightning arresters should be used on inputs and outputs when there is a danger from this source.
- (5) Refer to diagrams for connection details.

RS422/485 COMMS CABLING.

- (1) Use only low capacitance, twisted pair, overall screened data cable. The cable must equal or better the following specifications.

Cable Specifications.		
Conductor Size.		7/0.20mm, 24AWG
Conductor Resistance @ 20C.		8.9Ω/100m
Max. Working Voltage.		300Vrms
Capacitance between wires of a pair.		50pF/m
Capacitance between each wire to all others bunched together.		95pF/m
Cross-talk between pairs:	@ 1kHz @ 100kHz	>-90dB/100m >-50dB/100m
Characteristic Impedance .	@ 100kHz	135Ω
Attenuation of a pair:	@ 1kHz @ 10kHz @ 100kHz @ 150kHz @ 1MHz @ 1.5MHz	0.15dB/100m 0.42dB/100m 0.8dB/100m 0.9dB/100m 1.9dB/100m 2.4dB/100m

NOTE: All cables are to be subject during manufacture to in-process spark testing @ 4kVrms.
All cables are to be tested between conductors and conductors to screen for 1min @ 1500Vrms.

- (2) Minimum cable pairs: RS422 = 2. (Plus overall screen.)
RS485 = 1. (Plus overall screen.)
- (3) Take care not to stress or damage cables during installation.
- (4) Total length of trunk line, including spurs, is not to exceed 1200m without isolating boosters.
- (5) Terminating resistors -1kΩ.
- (6) Cabling paths should avoid sources of radio frequency interferences such as fluorescent lights, variable speed motor drives, welding equipment, radio transmitters, etc.
- (7) There should be a minimum of 200mm physical separation between power cables and data cables.
- (8) Data cables should not be exposed to excessive heat or moisture, and should not be buried directly in the ground without protection.
- (9) Avoid powering a remote station or controller from the same power supply as a variable speed drive.



P.O. Box 60, Thompson Ridge, NY 10985 ☆ 800-49-VESPO ☆ 800-36-VESPO (Fax)
Website: WWW.VESPO.COM ☆ E-mail: controls@vespo.com