SD16 Series
Digital Indicator

Instruction Manual

Thank you for purchasing the Shimaden SD16 Series. Please check that the delivered product is the correct item you ordered. Please do not begin operating this product until you have read this instruction manual thoroughly and understand its contents.

Notice

Please ensure that this instruction manual is given to the final user of the instrument.



Preface

This instruction manual is meant for those who will be involved in the wiring, installation, operation and routine maintenance of the SD16 series.

This manual describes items concerning safety cautions, installation, wiring, functions and operating method for SD16 series. Always keep this manual close at hand when handling this instrument.

Please observe the descriptions in this manual whenever you use this instrument.

Matters of attention concerning safety, damages on machines and equipment, additional explanations and commentaries are described under the following headings.

WARNING

Items concerning matters that may lead to an accident involving human injury or death, if the warning is not observed.

CAUTION

Items concerning matters that may lead to an accident involving damages to machines or equipment, if the caution is neglected.

Note

Additional explanations and commentaries.

The symbol  expresses the terminal of protective conduction. Please make sure to arrange wire connection for grounding.

Safety Cautions

WARNING

SD16 series indicator is designed to indicate temperature, humidity and other physical data of general industrial equipment. Do not apply this instrument to other objects in a way that may give grave effects on safety of human life. For such uses involving possible risks, proper safety measures have to be provided. In case of an accident by operation without safety countermeasures, sellers shall not take any responsibility.



WARNING

- In using this product, be certain to house it, for example, in a control panel so that the terminals cannot come into contact with personnel.
- Do not take this instrument out of the case or put your hand or any conductor inside the case. Such conduct may lead to an accident which endangers life or causes serious injury due to electric shock.
- Do not fail to ground the earthing terminal in use.

CAUTION

To avoid damage to the connected equipment, facilities or the product itself due to a fault of the product, safety countermeasure must be taken before usage, such as proper installation of the fuse and the overheating protection device. No warranty, express or implied, is valid in the case of usage without having implemented proper safety countermeasures.

CAUTION

- Regarding the alert symbol mark  on the plate attached to this instrument:
On the terminal nameplate attached to the case, an alert symbol  is printed. This is to give a caution not to touch the electrical charging part when power is being supplied so as to avoid the risk of electrical shock.
- Install a switch or breaker on the external source power circuit connecting to the source power terminal as a means of shutting down the power.
The switch or breaker should be installed adjacent to the instrument at a position which allows easy access of the operator. Put up a sign indicating that this switch is for shutting down the power of the instrument.
- Regarding the fuse:
Since this instrument has no built-in fuse, make sure to install a fuse in the electric circuit connecting to the source power terminal.
Install the fuse at a position between the switch or breaker and the instrument and attach it to the L side of the source power terminal.
Fuse Rating: 250V AC 1.0A/Time-lag(T), Low-breaking capacity (L)
Use a fuse which meets the requirements of IEC127.
- The load of voltage and current to be applied to the output terminal (analog output) and the alarm terminal have to be within the rated range. If the range is exceeded, the instrument will overheat and, as a result, there is a risk of the instrument being damaged and the life reduced.
As for the rating, please refer to "7. Specification" on page 8.
The unit connected to the output terminal should conform to the requirements of IEC1010.
- Do not apply over-rated voltage or current to the input terminal. There is a risk of the instrument being damaged and the life reduced.
As for the rating, please refer to "7. Specification" on page 8.
In case the input type is voltage (mV or V) or current (4 ~ 20mA), the unit connected to the output terminal should conform to the requirements of IEC1010.
- The instrument has a ventilating hole for heat radiation. Take care to prevent metal or other foreign matter from obstructing it. It will cause damages to the instrument and may even result in fire.
- Do not block the ventilating hole. Also avoid dust accumulation. Any rise in temperature or insulation failure may result in a shortening of the life of product and/or problems with the product. As for the clearance space for installing the instrument, refer to "2-3 External dimensions and panel cutout" on page 4.
- Repeating withstanding tests on voltage, noise, surging may lead to deterioration of the instrument. Please be careful.
- Strictly refrain from remodeling and using the instrument improperly.

CONTENTS

	Page
1. Introduction	3
1-1. Check before use	3
1-2. Caution for use	3
2. Installation and wiring	3
2-1. Installation site (environmental conditions)	3
2-2. Mounting	3
2-3. External dimensions and panel cutout	4
2-4. Wiring	4
2-5. Terminal arrangement	4
2-6. Terminal arrangement table	4
3. Instruction for front panel	4
3-1. Front illustration and the name of parts	4
3-2. Instruction for front panel	4
4. Explanation of each screen	5
4-1. List of screen sequence	5
4-2. Mode 0 screen group	6
4-3. Mode 1 screen group	6
4-4. Table of measuring range code	7
4-5. Table of alarm type code	7
4-6. Method of shifting screens	7
5. Supplementary explanation	7
5-1. Display update cycle (Screen No.1-2)	7
5-2. Alarm output action (option)	7
5-3. Analog output action (option)	7
5-4. Auto-return function	7
6. Error message	7
7. Specification	8

1. Introduction

1-1. Check before use

The instrument passes thorough quality checks before shipment. When the instrument is delivered, please confirm the type code number, then check the external conditions and the list of accessories. Make sure that there are no apparent damages or discrepancies.

Confirmation of the type code: Collate the type code printed on the label attached to the packing case with the following schema and confirm that the delivered goods meet your order.

SD16- 8 90- 0 0 0 0	Item	Reference code and contents
8	1. Series	SD16 : 48 × 96 DIN size Digital Indicator
90	2. Input	8: Multi-input, thermocouple, R.T.D., Voltage (mV, V), Current (mA)
0	3. Power supply	90-: 100 – 240V AC ±10% (50/60Hz) 08-: 24V AC (50/60Hz)/DC ±10%
0	4. Alarm (option)	0: None 1: Alarm output
0	5. Analog output (option)	0: None 3: 0~10mV DC (output resistance 10Ω) 4: 4~20mA DC (load resistance 300Ωmax.) 6: 0~10V DC (load current 1mA max.)
0	6. Communication (option)	0: None 5: RS-485 7: RS-232C
	7. Remarks	0: Without 9: With

Accessory list check:

Instruction Manual	1 copy
Unit decal	1 sheet
Communication Instruction Manual	1 copy

(In case of optional communication selected)

Note: Contact our representative concerning any problems with the product, accessories or related items.

1-2. Caution for use

- (1) Avoid operating keys of the front panel with hard or sharp objects or motions. Lightly touch the operating keys with finger tip for operation.
- (2) When cleaning, do not use solvent like thinner. Wipe the instrument with dry cloth lightly.

2. Installation and wiring

2-1. Installation site (environmental conditions)



Do not install the instrument at a place of environmental conditions as listed below. Otherwise, it will cause damages to the instrument and may even result in fire.

- (1) Where flammable or corrosive gas, oil soot or dust that deteriorates insulation is generated or abundant.
- (2) Where ambient temperature is below -10°C or above 50°C.
- (3) Where ambient humidity is higher than 90% RH, or below dew point.
- (4) Where strong vibrations or impact is generated or transferred.
- (5) Where there is a high-tension electrical circuit in the neighborhood, or induction interference.
- (6) Where under exposure to direct sun light or dew drops.
- (7) Where the elevation is higher than 2000m.
- (8) Outdoors

Note: The environmental conditions belong to the installation category II of IEC 664 and the degree of pollution is 2.

2-2. Mounting

- (1) Cut a fitting hole by referring to the panel cutout plan in item 2-3.
- (2) Applicable thickness of the panel is 1.0 ~ 4.0mm.
- (3) The instrument has catching claws to fix it in position. Just push it in from the front panel.

Note: SD16 is a panel installation type indicator. When the instrument is used, make sure to mount it on a panel.

2-3. External dimensions and panel cutout

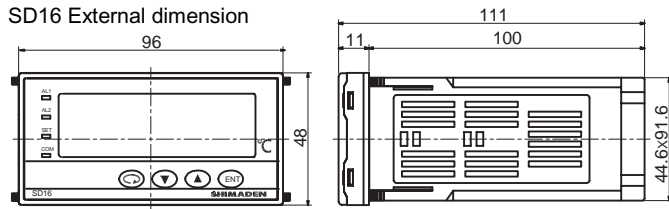

SD16 External dimension

2-4. Wiring



- When making wire arrangement, be sure to cut the power supply OFF. There is a risk of electric shock.
- Make sure the protective conductor terminal (⊕) is grounded. Otherwise, a serious electric shock may result.
- After completing wiring arrangement, do not touch the terminals and electrically charged parts while power is ON.

- (1) Arrange wiring according to the terminal layout in item 2-5 and the terminal arrangement table in item 2-6. Confirm that all connections are made correctly.
- (2) Use crimp-style terminals of 7mm or narrower width to meet M3.5 screws.
- (3) In case of thermocouple input, use a compensation wire with the type of thermocouple selected. The external resistance should be 100Ω or less.
- (4) In case of R.T.D. input, the resistance value per lead wire should be 5Ω or less and all the 3 wires should have the same resistance value.
- (5) Avoid arranging the input signal line to pass through in the same conduit or duct with high-tension circuit.
- (6) Shield wire (one-point grounding) is effective to eliminate the electrostatic induction noises.
- (7) An effective way of eliminating the magnetic induction noises is to twist the input wire in short and equal intervals.
- (8) For source power connection, use wire or cable having a cross section of 1mm² or larger and performance capacity equivalent to 600V vinyl insulation wire.
- (9) Grounding wire should have a cross section of 2mm² or larger and the grounding work should ensure ground resistance of 100Ω or less.
- (10) Screw up the terminal connection securely. Tightening torque 1.0N·m (10kgf·cm)
- (11) Noise filter
In case the instruments are affected by the power supply noise, install a noise filter to avoid operation errors. Mount the noise filter on the grounded panel and connect the noise filter output and the power supply terminal of the indicator with shortest possible distance.

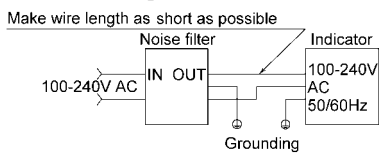

Recommended noise filter: TDK product ZMB2203-13

2-5. Terminal arrangement

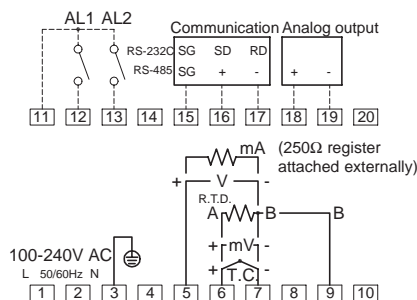

2-6. Terminal arrangement table

Name of terminal and contents	Terminal No.
Power supply terminal 100 – 240V AC ± 10% 50/60Hz 11VA 24V DC 7W/24V AC ± 10% 50/60Hz 11VA	1-2
Protective conductor terminal (⊕)	3
Input terminal Voltage (V)· Current: + R.T.D. A, thermocouple/voltage (mV): + R.T.D. B, thermocouple/voltage (mV, V)· current: – R.T.D. B	5 6 7 9
Alarm output (option) terminal COM contact point rating 240V AC, 1.5A (load resistance) AL1 AL2	11 12 13
Communication (option) terminal SG, SG SD, + RD, –	15 16 17
Analog output (option) terminal + –	18 19

Note: In case of thermocouple, voltage and current input, keep terminal No. 9 open.

3. Instruction for front panel

3-1. Front illustration and the name of parts

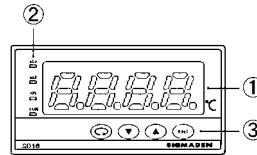

Name of each part

- ① Display part for measured value
- ② LED for monitoring
- ③ Key switch operating part

3-2. Instruction for front panel



- ①: Display part for measured value (red)
 - Mode 0, Current PV value is displayed on the basic screen.
 - Type of parameters is displayed on each parameter character screen.
 - Set value is displayed on each parameter setting screen.
- ②: LED for monitoring
 - (1) AL1 (Alarm 1) output monitoring LED (red)
 - LED lights when an assigned alarm is ON.
 - (2) AL2 (Alarm 2) output monitoring LED (red)
 - LED lights when an assigned alarm is ON.
 - (3) SET (parameter setting) monitoring LED (green)
 - LED lights when screen display is other than the basic screen.
 - (4) COM (communication) monitoring LED (green)
 - LED lights when communication mode is on remote control.
- ③: Key switch operating part
 - (1) (Parameter key)
 - By pressing this key, display changes from a screen to the next in each screen group.
 - By pressing this key for 3 seconds or longer, the key works as the shifting key to shift the screen from the basic screen of Mode 0 screen group to the initial parameter screen of Mode 1 screen group.
 - (2) (down) key
 - By pressing this key on each screen, the decimal point of the last digit blinks and the data value is decreased or the decimal point shifts downward.
 - (3) (up) key
 - By pressing this key on each screen, the decimal point of the last digit blinks and the data value is increased or the decimal point shifts upward.
 - (4) (entry/register) key
 - This key works for mutual shifting between the parameter character display screen and the parameter setting screen. (when light of the decimal point of the last place is OFF)
 - On each screen of Mode 0 and Mode 1 screen groups, the data changed by the (up) or (down) key is established. (when light of the decimal point of the last place is also OFF)

4. Explanation of each screen

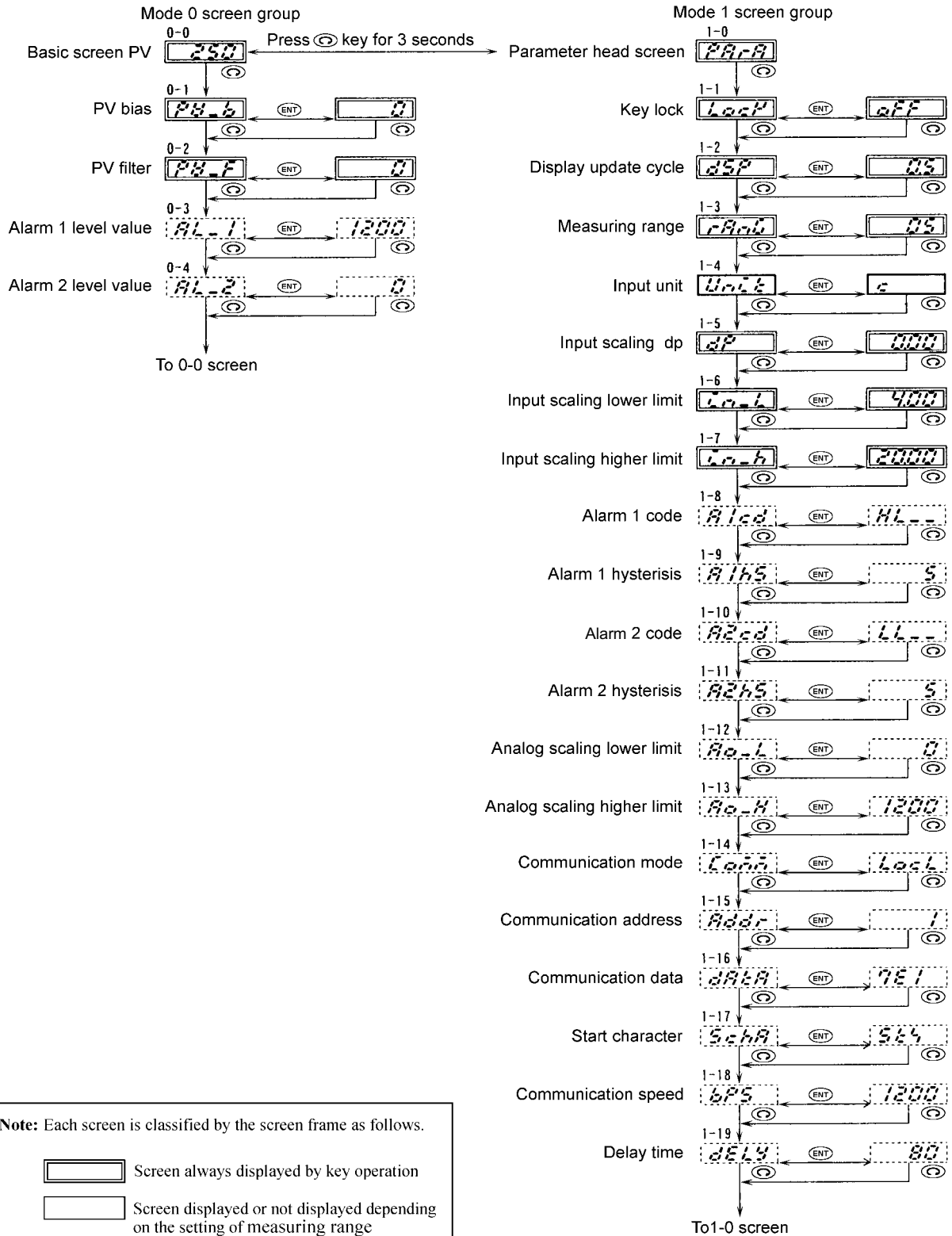
4-1. List of screen sequence



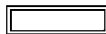

Note: Each screen is classified by the screen frame as follows.

-  Screen always displayed by key operation
-  Screen displayed or not displayed depending on the setting of measuring range
-  Screen displayed when options of alarm, communication and analog output are added

Note: When the type of alarm is changed, the setting values are initialized.

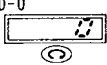

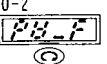
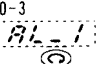
4-2. Mode 0 screen group

- 0-0  Basic screen
Current PV value is indicated.
- 0-1  PV bias value setting screen
Initial value: 0 or 0.0, Setting range: -200 ~ 200 unit
Used for compensating input errors by sensor, etc.
When bias is applied, compensated PV indication value is displayed.
- 0-2  PV filter time setting
Initial value: 0 second
Setting range: 0 ~ 100 seconds
Used for reducing the effect of excessive input fluctuation and repeating noise.
- 0-3  Alarm 1 level setting screen
This screen is displayed when the following setting code is selected on the code selection screen of Mode 1 setting screen. On this screen, setting of alarm action point is available.
In case of the system without alarm option, this screen is not displayed.

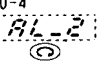
Alarm type	Code	Initial value	Setting range
Higher limit	HL_, HL_S	Higher limit value	Within range
Lower limit	LL_, LL_S	Lower limit value	Within range

- 0-4  Alarm 2 level setting screen
Same as the above Alarm 1 setting screen

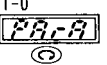
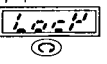
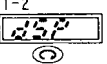
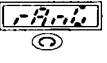
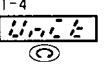
4-3. Mode 1 screen group

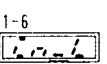
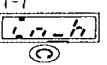
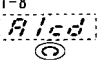
- 1-0  Parameter initial screen
This is the heading screen of Mode 1.
- 1-1  Key lock mode setting screen
Initial value: OFF, Setting range: OFF, ON
When key lock ON is set, data is protected and cannot be changed.
- 1-2  Indication renewal time setting screen
Initial value: 0.5 second
Setting range: 0.5 ~ 5.0 seconds
Setting of the time of renewing PV value indication is made on this screen. Time is set by every 0.5 second.
- 1-3  Measuring range selecting screen
Initial value: 05
Setting is made by selecting the code from the measuring range code table in item 4-4.
- 1-4  Input unit setting screen
Initial value: °C, Unit selection: °C or °F
The input unit is selected.
In case of linear input (mV, V, mA), this screen is not displayed.
- 1-5  Input scaling decimal point position
Initial value: 0.0
Setting range: No decimal point, 0.0, 0.00, 0.000
The decimal point setting is made at the time of linear input (mV, V, mA) scaling.
For sensor input, this setting is not possible, where monitoring only will do.
- 1-6  Input scaling lower limit
Initial value: 0.0, Setting range: -1999 ~ 9999 units
The lower limit value setting is made at the time of linear input (mV, V, mA) scaling.
The span with the higher limit = 10 ~ 5000 counts
Reverse scaling is possible.
For sensor input, this setting is not possible, where monitoring only will do.
For details, refer to item 4-6 (4).
- 1-7  Input scaling higher limit
Initial value: 100.0
Setting range: -1999 ~ 9999 units
The higher limit value setting is made at the time of linear input (mV, V, mA) scaling.
The span with the lower limit = 10 ~ 5000 counts
Reverse scaling is possible.
For sensor input, this setting is not possible, where monitoring only will do.
For details, refer to item 4-6 (4).
- 1-8  Alarm 1 code Initial value: HL_
Selected from alarm type code table in item 4-5.
In case of the system without alarm option, this screen is not displayed.

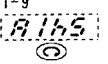
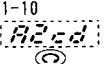
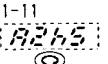
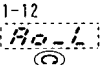
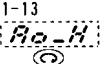
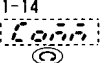
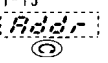
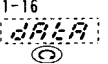
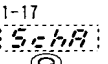
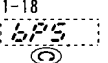
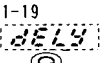
- 1-9  Alarm 1 hysteresis
Initial value: 5 unit, Setting range: 1 ~ 999 unit
This screen is for setting Alarm 1 hysteresis.
In case of the system without alarm option, this screen is not displayed.
- 1-10  Alarm 2 code Initial value: LL_
Selected from alarm type code table in item 4-5.
In case of the system without alarm option, this screen is not displayed.
- 1-11  Alarm 2 hysteresis
Initial value: 5 unit, Setting range: 1 ~ 999 unit
This screen is for setting Alarm 2 hysteresis.
In case of the system without alarm option, this screen is not displayed.
- 1-12  Analog output lower limit value scaling
Initial value: Measuring range lower limit value
Setting range: Lower limit ~ higher limit of measuring range
Setting of lower limit value of analog output scaling is made.
Span with higher limit value = 1 count
Reverse scaling is possible.
In case of the system without analog output option, this screen is not displayed.
For details, refer to item 4-6 (5).
- 1-13  Analog output higher limit value scaling
Initial value: Measuring range higher limit value
Setting range: Lower limit ~ higher limit of measuring range
Setting of higher limit value of analog output scaling is made.
Span with lower limit value = 1 count
Reverse scaling is possible.
In case of the system without analog output option, this screen is not displayed.
For details, refer to item 4-6 (5).
- 1-14  Communication mode
Initial value: Loc (local), Setting range: Loc, Com
Communication mode is set.
Front key operation can change Com → Loc only.
For details, refer to separate Instruction Manual for communication.
In case of the system without communication option, this screen is not displayed.
- 1-15  Communication address
Initial value: 1, Setting range: 1 ~ 255
When plural machine is connected, the number of the machines is set.
For details, refer to separate Instruction Manual for communication.
In case of the system without communication option, this screen is not displayed.
- 1-16  Communication data
Initial value: 7E1, Setting range: 7E1, 8N1
Setting of communication data format is set.
For details, refer to separate Instruction Manual for communication.
In case of the system without communication option, this screen is not displayed.
- 1-17  Start character
Initial value: STX, Setting range: STX, ATT
The character at the head of communication is set.
For details, refer to separate Instruction Manual for communication.
In case of the system without communication option, this screen is not displayed.
- 1-18  Communication speed
Initial value: 1200bps
Setting range: 1200, 2400, 4800, 9600, 19200bps
Transmitting speed of communication data is set.
For details, refer to separate Instruction Manual for communication.
In case of the system without communication option, this screen is not displayed.
- 1-19  Delay time
Initial value: 80, Setting range: 0 ~ 500
The delay time from receipt of communication command till starting transmission is set.
Delay time = 0.1 × Setting value (in milli-second)
For details, refer to separate Instruction Manual for communication.
In case of the system without communication option, this screen is not displayed.

4-4. Table of measuring range code

Input type	Code	Measuring range	
		°C	°F
Thermo-couple	B	0 ~ 1800	0 ~ 3300
	R	0 ~ 1700	0 ~ 3100
	S	0 ~ 1700	0 ~ 3100
	K	-199.9 ~ 800.0	-300 ~ 1500
	K	0 ~ 1200	0 ~ 2200
	E	0 ~ 700	0 ~ 1300
	J	0 ~ 600	0 ~ 1100
	T	-199.9 ~ 300.0	-300 ~ 600
	N	0 ~ 1300	0 ~ 2300
	*1 U	-199.9 ~ 300.0	-300 ~ 600
	*1 L	0 ~ 600	0 ~ 1100
	*2 WRe5-26	0 ~ 2300	0 ~ 4200
R.T.D.	Pt100	31	-200 ~ 600 -300 ~ 1100
		32	-100.0 ~ 100.0 -150.0 ~ 200.0
Voltage	0 ~ 10mV	Initial value: 0.0 ~ 100.0	
	0 ~ 5V	Scaling range: -1999 ~ 9999 count	
	1 ~ 5V	Span: 10 ~ 5000 count	
	0 ~ 10V		
Current	4 ~ 20mA	35	

Thermocouple: B, R, S, K, E, J, T, N: JIS/IEC
 *1 Thermocouple U, L: DIN43710
 *2 Thermocouple WRe5-26: Hoskins product
R.T.D. Pt100: New JIS/IEC

Note: When the measuring range is changed, data related to measuring range, such as set value and alarm setting value are initialized.

4-5. Table of alarm type code

Alarm code can be assigned each for AL1 and AL2 independently.

Alarm code	Alarm type	Inhibit action	*1 Communic ation	Remarks
HL	Higher limit absolute value	No	1	
HL_S	Higher limit absolute value	Yes	2	Output ON, also in case of sensor breakage or higher limit scale-over
LL	Lower limit absolute value	No	3	
LL_S	Lower limit absolute value	Yes	4	Output ON, also in case of lower limit scale-over

*1 During communications, Read and Write become possible at the above values.

4-6. Method of shifting screens

- Method of shifting between Mode 0 screen group and Mode 1 screen group
 - By pressing the key on the basic screen for 3 seconds or longer, the display changes to the parameter heading screen of Mode 1 screen group. To return to the basic screen, keep pressing the key again for 3 seconds or longer.

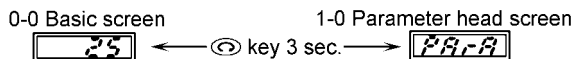

- Method of shifting screen within Mode 0 screen group
 - By each pressing of the key, screen shift takes place.
 - When the light of decimal point of the lowest digit place is OFF, by each pressing of key, the screen shifts alternately between the parameter character indicating screen and the parameter setting screen.
- Method of shifting screen within Mode 1 screen group
 - By each pressing of the key, screen shift takes place.
 - When the light of decimal point of the lowest digit place is OFF, by each pressing of key, the screen shifts alternately between the parameter character indicating screen and the parameter setting screen.
- Method of setting input scaling screen in Mode 1 screen group
 - On condition that "Lower limit value < Higher limit value", when the lower limit value is set with a difference less than 10 counts from that of the higher limit value, the higher limit value is forcibly changed to a new value at lower limit value plus 10 counts. As a result, when the higher limit exceeds 9999 counts, it is changed to the value of the lower limit value minus 10 counts. Also, when a lower limit value is set at a value with a difference exceeding 5000 counts from the higher limit value, the higher limit value is forcibly changed to a new value at lower limit value plus 5000 counts (-5000 counts).
 - On condition that "Lower limit value < Higher limit value", when the higher limit value is set with a difference less than 10 counts from that of the higher limit value, the lower limit value is forcibly changed to a new value at higher limit value minus 10 counts. As a result, when the lower limit exceeds -1999 counts, it is changed to the value of the higher limit value plus 10 counts. Also, when a higher limit value is set at a value with a difference exceeding 5000 counts from the lower limit value, the lower limit value is forcibly changed to a new value at higher limit value minus 5000 counts (+5000 counts).
 - On condition that "Lower limit value > Higher limit value", when the lower limit value is set with a difference less than 10 counts from that of the higher limit value, the higher limit value is forcibly changed to a new value at lower limit value minus 10 counts. As a result, when the higher limit exceeds -1999 counts, it is changed to the value of the lower limit value plus 10 counts. Also, when a lower limit value is set at a value with a difference exceeding 5000 counts from the higher limit value, the higher limit value is forcibly changed to a new value at lower limit value minus 5000 counts (+5000 counts).
 - On condition that "Lower limit value > Higher limit value", when the higher

limit value is set with a difference less than 10 counts from that of the higher limit value, the lower limit value is forcibly changed to a new value at higher limit value plus 10 counts.

As a result, when the lower limit exceeds 9999 counts, it is changed to the value of the higher limit value minus 10 counts. Also, when the higher limit value is set at a value with a difference exceeding 5000 counts from the lower limit value, the lower limit value is forcibly changed to a new value at higher limit value plus 5000 counts (-5000 counts).

- Method of setting analog output scaling screen in Mode 1 screen group
 - On condition that "Lower limit value < Higher limit value", when the lower limit value is set at the same value of the higher limit, the higher limit value is automatically changed to the lower limit value +1 count. As a result, when the higher limit exceeds the higher limit of the measuring range, it is changed to the value of lower limit -1 count.
 - On condition that "Lower limit value < Higher limit value", when the higher limit value is set at the same value of the lower limit, the lower limit value is automatically changed to the higher limit value -1 count. As a result, when the lower limit exceeds the lower limit of the measuring range, it is changed to the value of higher limit +1 count.
 - On condition that "Lower limit value > Higher limit value", when the lower limit value is set at the same value of the higher limit, the higher limit value is automatically changed to the lower limit value -1 count. As a result, when the higher limit exceeds the lower limit of the measuring range, it is changed to the value of lower limit +1 count.
 - On condition that "Lower limit value > Higher limit value", when the higher limit value is set at the same value of the lower limit, the lower limit value is automatically changed to the higher limit value +1 count. As a result, when the lower limit exceeds the higher limit of the measuring range, it is changed to the value of higher limit -1 count.

5. Supplementary explanation

5-1. Display update cycle (Screen No.1-2)

- Setting of PV display update cycle on the basic screen is made.
- The setting of value is made every 0.5 second.

5-2. Alarm output action (option)

- Setting of alarm higher limit value
 - For setting the alarm higher limit value, the alarm hysteresis is set by selecting the higher limit alarm on the alarm code screen of Mode 1 screen group (when alarm option is attached).
 - The higher limit alarm is output when the process value exceeds the alarm level value. The output goes off when the process value comes down below the alarm level value minus the alarm hysteresis.
- Setting of alarm lower limit value
 - For setting the alarm lower limit value, the alarm hysteresis is set by selecting the lower limit alarm on the alarm code screen of Mode 1 screen group.
 - The lower limit alarm is output when the process value comes down below the alarm level value. The output goes off when the process value exceeds the alarm level value plus hysteresis.

5-3. Analog output action (option)

- The analog output is a function that outputs the analog voltage or analog current corresponding to the process value. They are used for input signal into a recorder and data accumulation equipment.
- Within the measuring range specified by the lower and higher limit value of the analog output scaling, analog output signal to correspond to the process value is available.

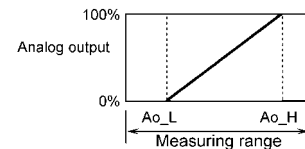

Scaling output diagram

5-4. Auto-return function

On any screen other than 0-0 basic screen, if no key operation is made for 3 minutes or longer, the screen shifts to the basic screen (auto-return).

6. Error message

Abnormal input of process value (indicated on the basic screen of Mode 0 screen group)

- This message is indicated when the thermocouple or A of R.T.D. is burnt out, also when PV value exceeds the higher limit of the measuring range by about 10%.
- When PV value is below the lower limit of the measuring range by about 10%, by reason such as wrong polarity of input wiring. When the Pt B (terminal No.7) wire breaks.
- When the cold junction (CJ) is abnormal on the higher side in thermocouple input.
- When the cold junction (CJ) is abnormal on the lower side in thermocouple input.
- When the B wire (terminal No.9) breaks, or when plural number of wires out of A · B · B break.

Note: When abnormality occurs, please contact our sales agent or to our business office directly.

7. Specification

Display

Digital display	: Process value (PV) 7 segment Red LED 4 digits
Action indication:	1 point of parameter display (SET) by green LED 1 point of communication display (COM) by green LED 2 points of alarm (AL1, AL2) by red LED
Display accuracy:	$\pm(0.3\% \text{ FS} + 1 \text{ digit})$ within measuring range Excluding cold junction temperature compensation accuracy in the case of thermocouple input $\pm 5\% \text{ FS}$ for temperature below 400°C of thermocouple B When the thermocouple [T, U] indication value is $-100 \sim 0^\circ\text{C}$, $\pm 0.5\% \text{ FS}$ and when it is below -100°C , $\pm 1\% \text{ FS}$
Display accuracy range	: $23^\circ\text{C} \pm 5^\circ\text{C}$ ($18 \sim 28^\circ\text{C}$)
Display resolution	: Depends on measuring range (0.001, 0.01, 0.1, 1)
Measured value display range	: $-10 \sim 110\%$ of measuring range (Accuracy guaranteed for value is within measuring range only) For R.T.D. input of $-200 \sim 600^\circ\text{C}$: $210 \sim 680^\circ\text{C}$ For thermocouple [K] input of $-199.9 \sim 800.0^\circ\text{C}$: $-273.1 \sim 900.0^\circ\text{C}$
Display update cycle	: $0.5 \sim 5.0$ seconds (0.5 Steps) When 0.5 second or more is set, there may occur a difference among the displayed value, the analog output and the communication data.

Setting

Setting	: By four (4) front key switches
Setting range	: Same as measuring range

Input

Type of input	: Multiple input of Thermocouple, R.T.D., Voltage (mV, V) and Current (mA)
Thermocouple	: B, R, S, K, E, J, T, N, {U, L (DIN43710)}, WRe5-26 Refer to measuring range code table.
External resistance	: 100Ω max.
Input impedance	: $500\text{K}\Omega$ min.
Burnout	: Standard feature (Up-scale)
Cold junction temperature compensation accuracy	: $\pm 1^\circ\text{C}$ ($18 \sim 28^\circ\text{C}$ range) $\pm 2^\circ\text{C}$ ($5 \sim 18^\circ\text{C}$, $28 \sim 45^\circ\text{C}$ range) ($\pm 5^\circ\text{C}$ to the negative side of measuring range in case of T and U input)
R.T.D.	: JIS Pt100 3-wire type
Amperage	: Approx. 0.25mA
Lead wire tolerable resistance	: 5Ω max. / wire (3 lead wire should have same resistance) When the resistance value of each wire is same $0 \sim 5\Omega$: 0.05°C max., $5 \sim 10\Omega$: 0.2°C max., $10 \sim 20\Omega$: 0.6°C max., $20 \sim 30\Omega$: 1.4°C max.
Voltage (mV)	: $0 \sim 10\text{mV}$ DC
(V)	: $0 \sim 5\text{V}$, $1 \sim 5\text{V}$, $0 \sim 10\text{V}$ DC
Input impedance	: $500\text{K}\Omega$ min.
Current	: $4 \sim 20\text{mA}$ DC
Input impedance	: 250Ω [A shunt resistor (option) needs to be connected to the terminal.]
Input scaling function	: Scaling possible for voltage (mV, V) or current (mA) input and inverse scaling possible.
Scaling range	: $-1999 \sim 9999$ count
Span	: $10 \sim 5000$ count
Position of decimal point	: None, 0.0, 0.00, 0.000
Sampling cycle	: 0.5 seconds
PV bias	: ± 200 unit
PV filter	: $0 \sim 100$ seconds (0 = without filter)
Isolation	: Between input and analog output

Alarm output (option)

Number of alarm points	: 2 (AL1 and AL2) for both normal open and common points
Alarm type	: Selectable from combinations of the following 4 types Higher limit absolute value without inhibit action Higher limit absolute value with inhibit action Lower limit absolute value without inhibit action Lower limit absolute value with inhibit action

Alarm setting range	: Within measuring range or within full scaling range
Alarm action	: ON-OFF action
Alarm sensitivity	: $1 \sim 999$ unit (within measuring range)
Alarm output/rating	: Contact 1a (common) / 240V , $\text{AC}1.5\text{A}$ (resistive load)
Alarm output update cycle	: 0.5 seconds

Analog output (option)

Analog output type	: $0 \sim 10\text{mV}$ (output resistance: 10Ω) $0 \sim 10\text{V}$ (load current: 1mA max) $4 \sim 20\text{mA}$ (load resistance : 300Ω max)
Output resolution	: Approx. 0.03% ($1/3000$)
Output accuracy	: $\pm(0.3\% \text{ FS} + 1 \text{ digit})$ of display value
Output scaling	: Within measuring range (inverse scaling possible)
Output update cycle	: 0.5 seconds

Communication (option)

Communication type	: RS-232C, RS-485
Communication system	: Half duplex start-stop synchronized system
Communication speed	: $1200, 2400, 4800, 9600, 19200$ bps
Data bit length	: 7 bit even parity 1 stop bit 8 bit non parity 1 stop bit
Communication address	: $1 \sim 255$
Multi-drop connection	: 31 max (with RS-485)
Communication delay	: $0 \sim 50.0$ milli-seconds

Others

Data storage	: By non volatile memory (EEPROM)
Ambient conditions for use	
Temperature/humidity	: $-10 \sim 50^\circ\text{C}/90\% \text{ RH}$ max (on condition that there is no dew condensation)
Height	: 2000m above sea level or lower
Installation category	: Category II
Degree of pollution	: Degree 2
Power supply voltage	: $100 \sim 240\text{V}$ $\text{AC} \pm 10\%$, $50/60\text{Hz}$ 24V $\text{AC}/\text{DC} \pm 10\%$
Power consumption	: 11VA (AC) max., 7W (DC) max.
Applicable standard	
Safety	: IEC1010-1, 1992
EMC	: EMI (emission) EN50081-2, 1993 EMS (immunity) EN50082-2, 1995 (EMC testing display accuracy: $\pm 5\% \text{ FS}$)
Dust proof/drip proof	: IP66 equivalent
Insulation resistance	: Between input/output terminal and power supply terminal: 500V DC $20\text{M}\Omega$ minimum Between input/output terminal and protective conductor terminal: 500V DC $20\text{M}\Omega$ minimum
Dielectric strength	: 1 min. at 2300V AC between input/output terminal and power supply terminal 1 min. at 1500V AC between power supply terminal and protective conductor terminal
Case material	: PPO resin molding (equivalent to UL94V-1)
External dimensions	: $\text{H}48 \times \text{W}96 \times \text{D}111$ mm
Mounting	: Push-in panel (one-touch mount)
Panel thickness	: $1.0 \sim 4.0$ mm
Panel cutout	: $\text{H}45 \times \text{W}92$ mm
Weight	: Approx. 250g

